

AI in Service- and Product Management

Andreas Windisch

**Joanneum Research, DIGITAL
Intelligent Vision Applications**

Webinar
8. April 2026

Defining (artificial) intelligence

“A human being should be able to change a diaper, plan an invasion, butcher a hog, conn a ship, design a building, write a sonnet, balance accounts, build a wall, set a bone, comfort the dying, take orders, give orders, cooperate, act alone, solve equations, analyze a new problem, pitch manure, program a computer, cook a tasty meal, fight efficiently, die gallantly. Specialization is for insects.”

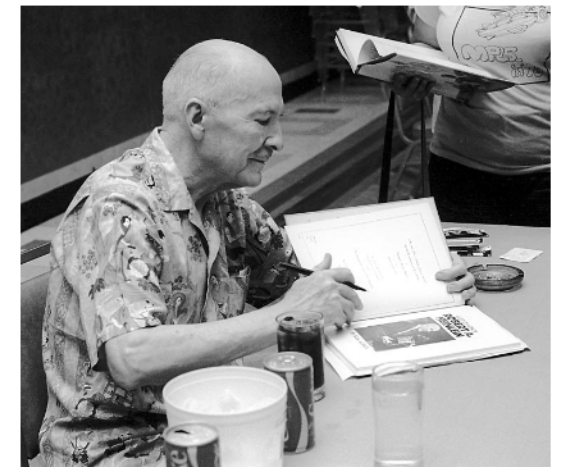

Source: wikipedia

Robert A. Heinlein, SciFi Author, 1907 - 1988

Global AI Revolution

Relying on existing laws and regulations

Introducing AI-specific legislative frameworks

Banning specific services (e.g. ChatGPT)

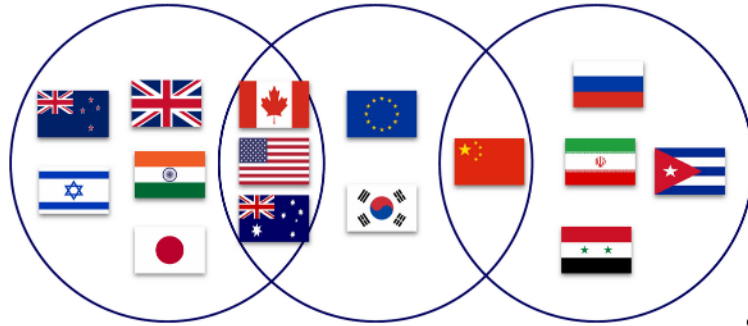

stateof.ai 2023

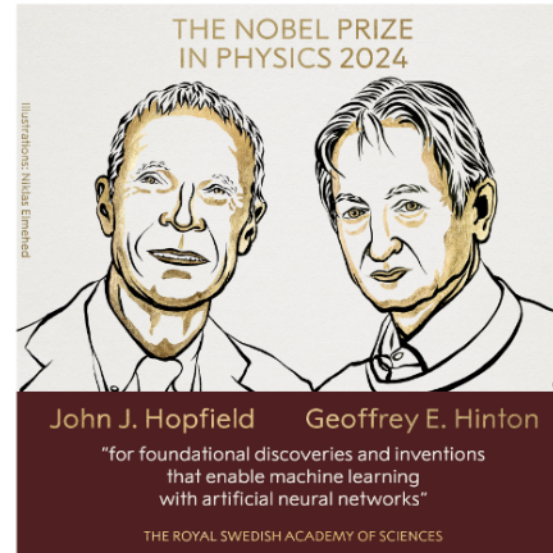

stateof.ai 2024

Artificial Neuron

1943

ELIZA chatbot

1966



Image Classification

2011

Transformer

2017

OpenClaw
Agentic AI

2026

Paper by Turing

1950

Computing Machines and Intelligence

Deep Blue

1997

Kasparov

Alpha Go

2016

World Champion

GPT4

2023

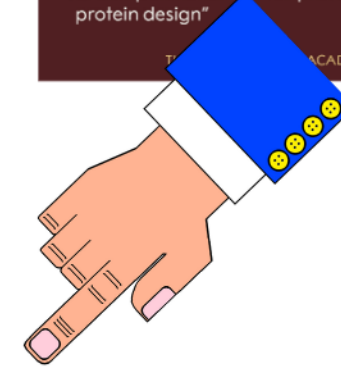

What Is AI? A Functional View

- Predict



They learn **patterns** in data and **forecast** what is likely to happen
(e.g., *energy demand, machine behavior, price curves, etc*)

- Optimize

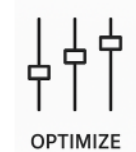

They find the **best settings, actions, or schedules** under constraints
(e.g., *reducing peaks, balancing loads, improving parameters, etc*)

- Detect



They identify **anomalies, defects, or inefficiencies** in real time
(e.g., *abnormal machine states, wear, unstable combustion, etc*)

Together, these capabilities let AI improve energy efficiency, stability, and throughput.

What Is AI? A Functional View

- Predict



They learn patterns in data and forecast what is likely to happen (e.g., energy demand, machine behavior, price curves, etc)

- Optimize



They find the best settings, actions, or schedules under constraints (e.g., reducing peaks, balancing loads, improving parameters, etc)

- Detect



They identify anomalies, defects, or inefficiencies in real time (e.g., abnormal machine states, wear, unstable combustion, etc)

Together, these capabilities let AI improve energy efficiency, stability, and throughput.

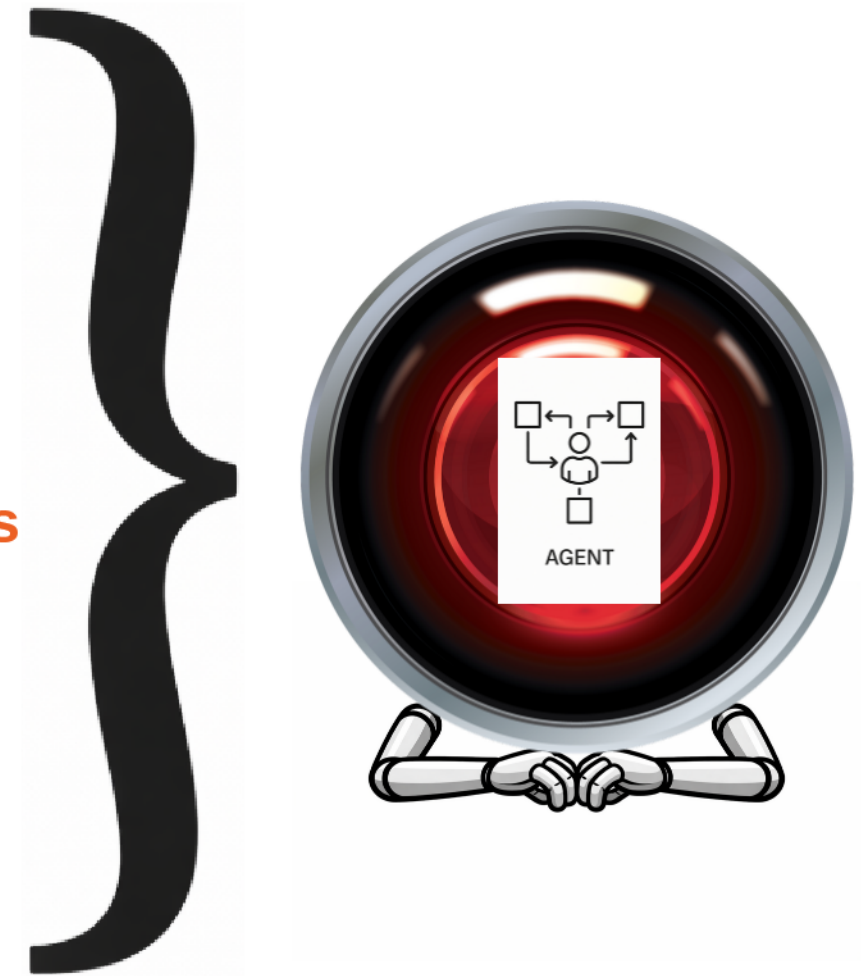



Use Case: Shop floor job scheduling

Vehicle Management in a modular production context using Deep-Q -Learning

L. Pouget, T. Hasenbichler, J. Auer, K. Lichtenegger, A. Windisch, [arXiv:2205.03294]

Source: <https://www.automotivemanufacturingsolutions.com/robotics/agvs-find-their-way/35016.article>

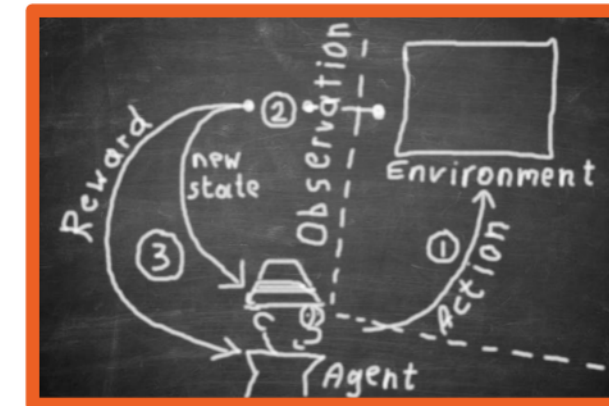
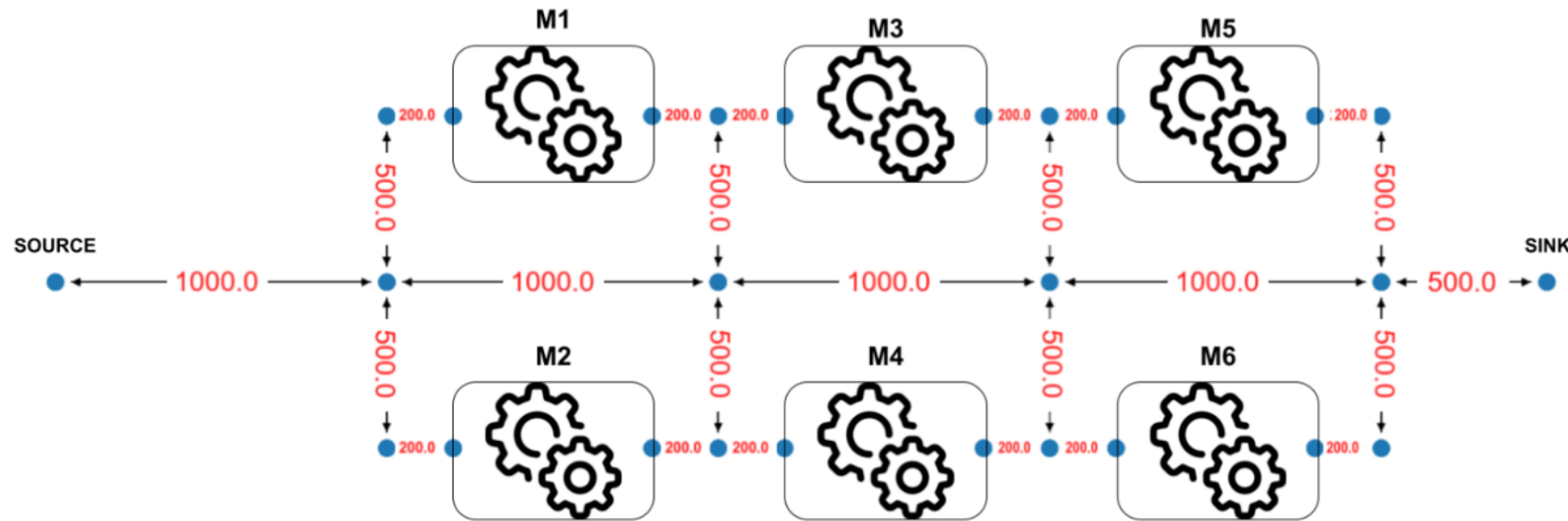

- Use reinforcement learning to optimally dispatch/schedule Automated Guided Vehicles on a modular production system
- Comparison with heuristic approaches
- Find comparable performance of Deep-Q
- Increased robustness to noise

Lower energy per part (optimal transport), machine utilization, robustness

Personalized marketing und product recommendations

- Identification of customer interests and preference

Enables personalized marketing and product recommendation

e.g. ~35% of purchases on Amazon come from product recommendations

- Data sources for personalization algorithms

Current shopping cart contents

Customer / customer group purchase history

Customer "likes" / "dislikes" on social media



Retrieval Augmented Generation (RAG)

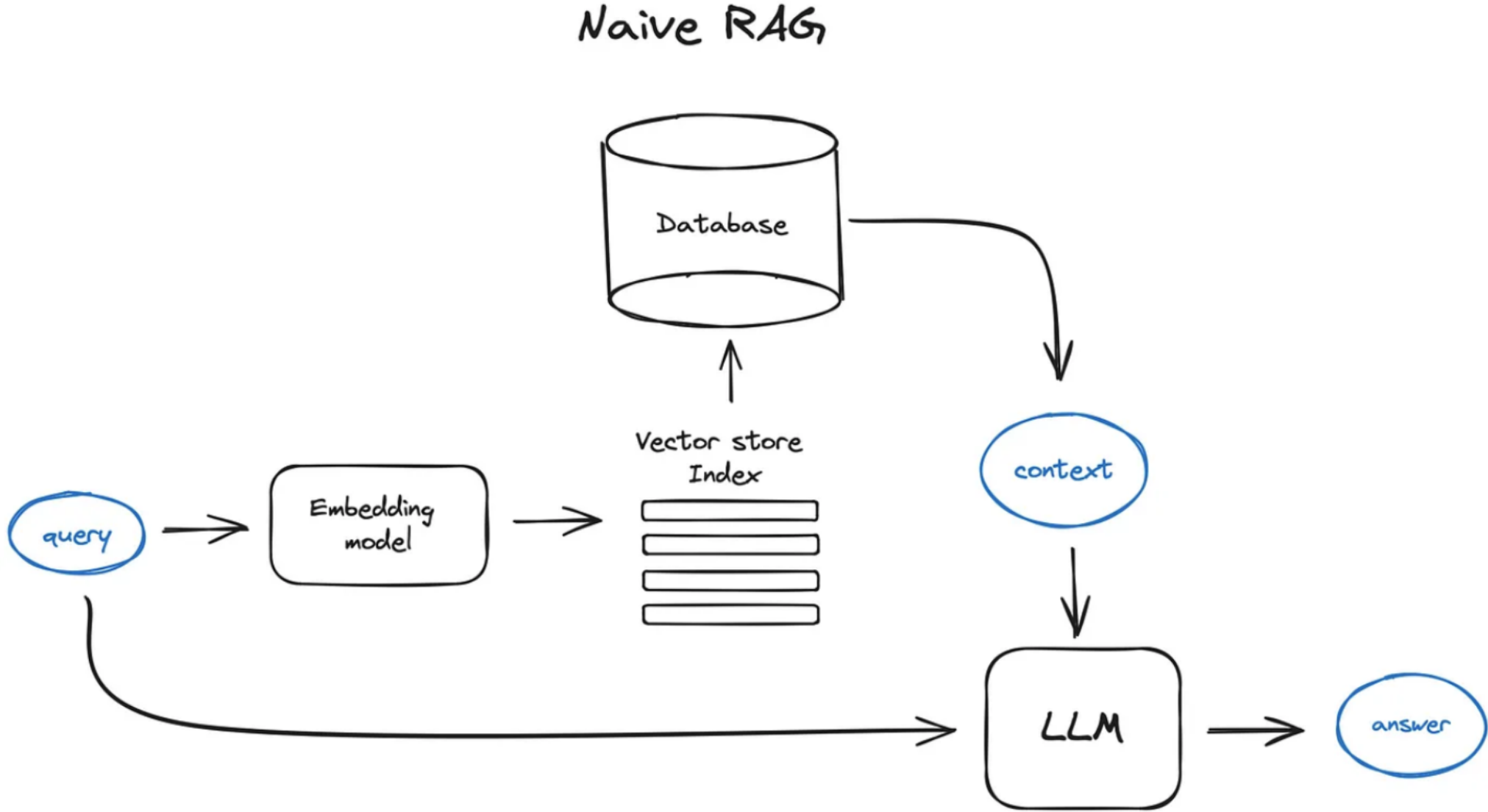

Source: Ivan Ilin, <https://pub.towardsai.net/advanced-rag-techniques-an-illustrated-overview-04d193d8fec6>

RAGxplain Pipeline

Deploying RAG*) Model for local knowledge management for quantum computing

*) RAG: Retrieval Augmented Generation

Scientific work
with formulas

$$i \hbar \frac{\partial \psi}{\partial t} = \hat{H} \psi$$



Automatic
Detection Service

$$i \hbar \frac{\partial \psi}{\partial t} = \hat{H} \psi$$



Adding additional
Descriptions

$$i \hbar \frac{\partial \psi}{\partial t} = \hat{H} \psi$$

Q: About Schroedinger Equation
A: The Schroedinger Equation explains ...



Extended
PDF Document

$$i \hbar \frac{\partial \psi}{\partial t} = \hat{H} \psi$$

The Schroedinger Equation explains ...



Local RAGxplain
Chat Service

Tell me about the
Schroedinger
Equation

The Schroedinger
Equation explains ...

VinoMon

Automated Monitoring of Grapevine Diseases Using 5G and AI

Stakeholders

- Winegrower
 - Cooperatives and associations (Genossenschaften)
 - Chamber of Agriculture, authorities (Länder)
- ### Objectives
- Automated vineyard and vine-row aerial surveying using 5G
 - AI based detection of vine rows and grapevine diseases (FD, Stolbur, Esca)
 - GIS with locations of diseased vines

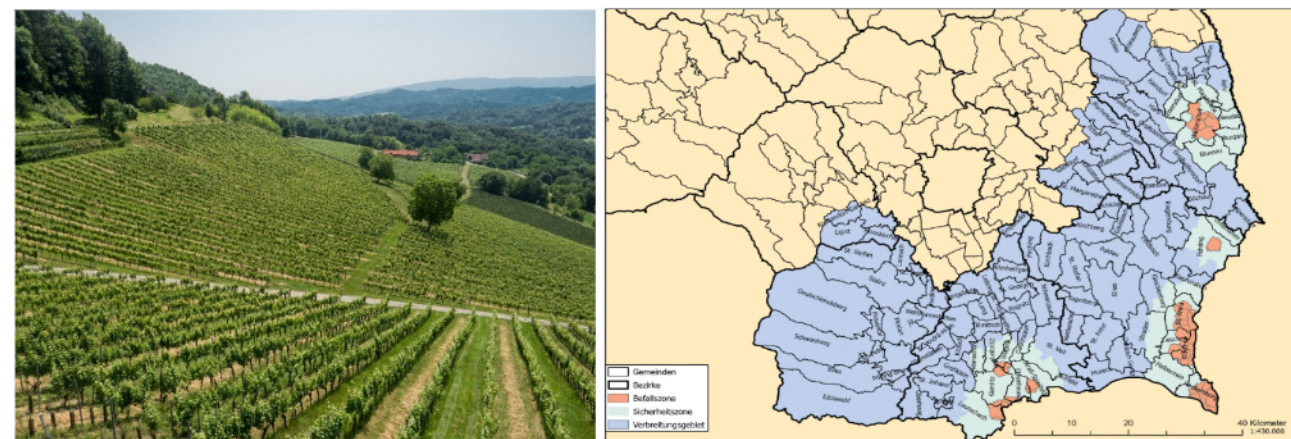

Flavescence Dorée (FD)

Stolbur

ESCA

Eisenmangel

*Across very different applications, the **pattern** is the same:*

- **AI creates value by** predicting, optimizing, or detecting
- **Energy efficiency improves as a side effect of** better decisions
- **Benefits often come from** reducing waste (time, material, scrap, idle states)
- **Improvements do not require new hardware: only** data and process access
- **AI works best when applied to a specific, well-defined use case**

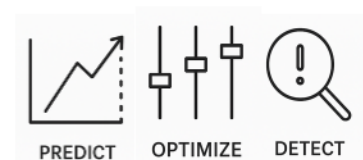
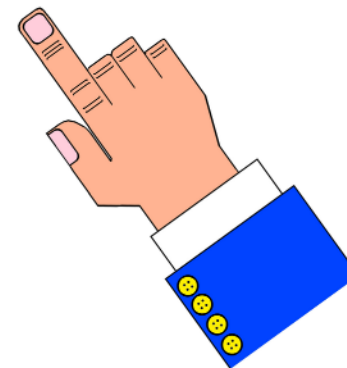

Energy efficiency emerges naturally when processes are optimized through AI

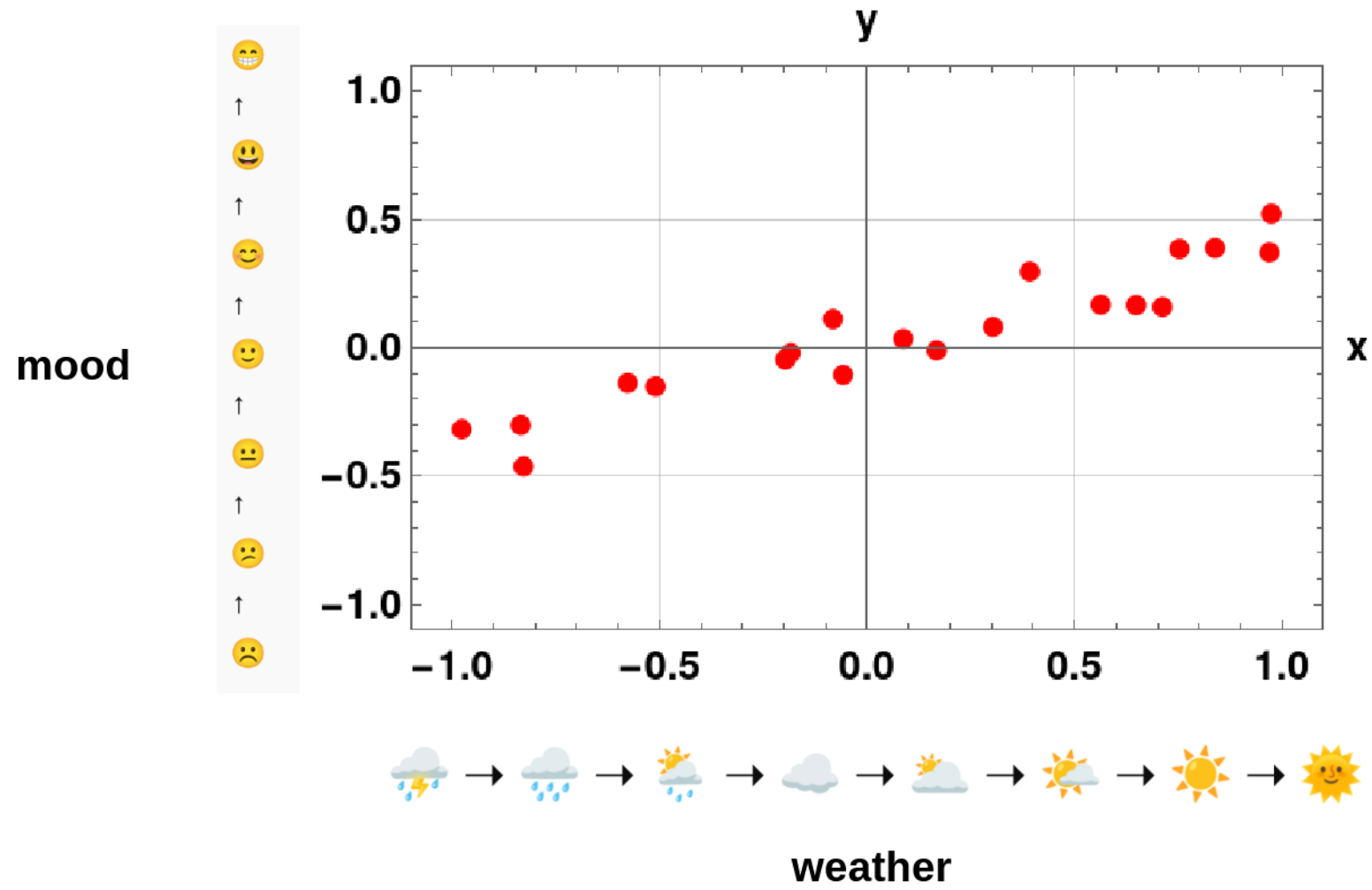

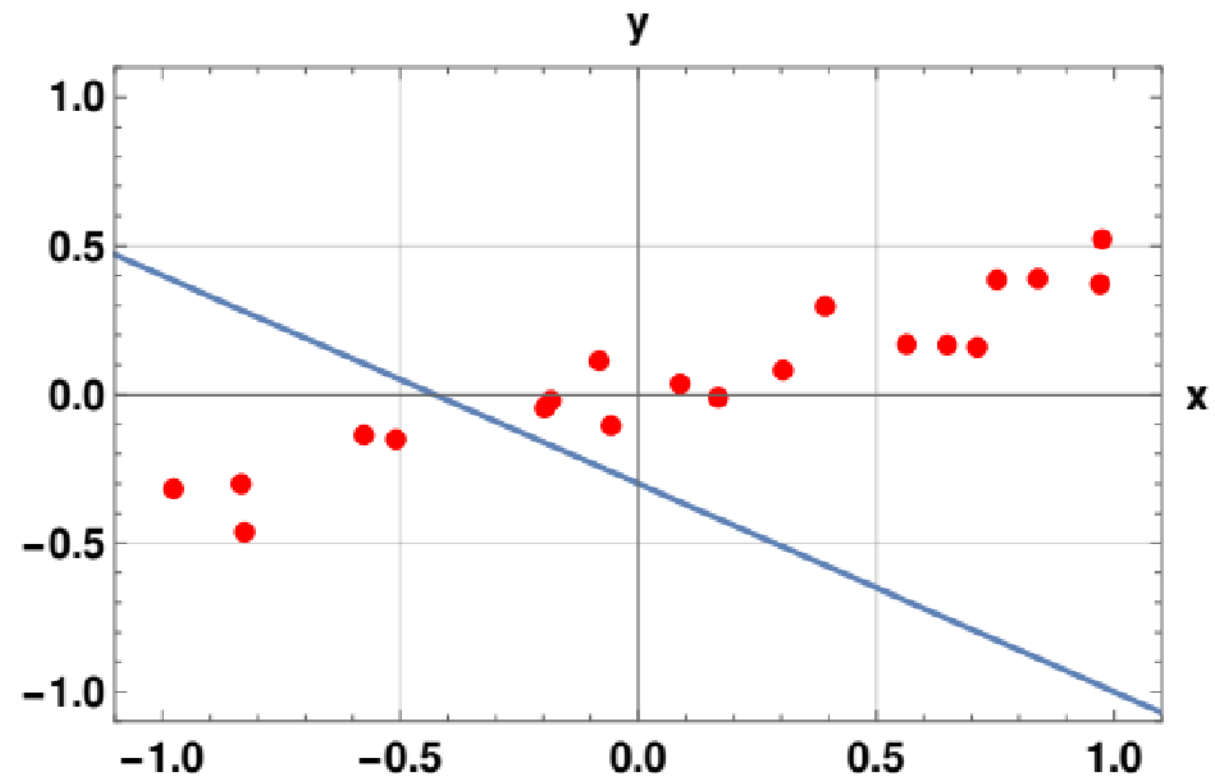

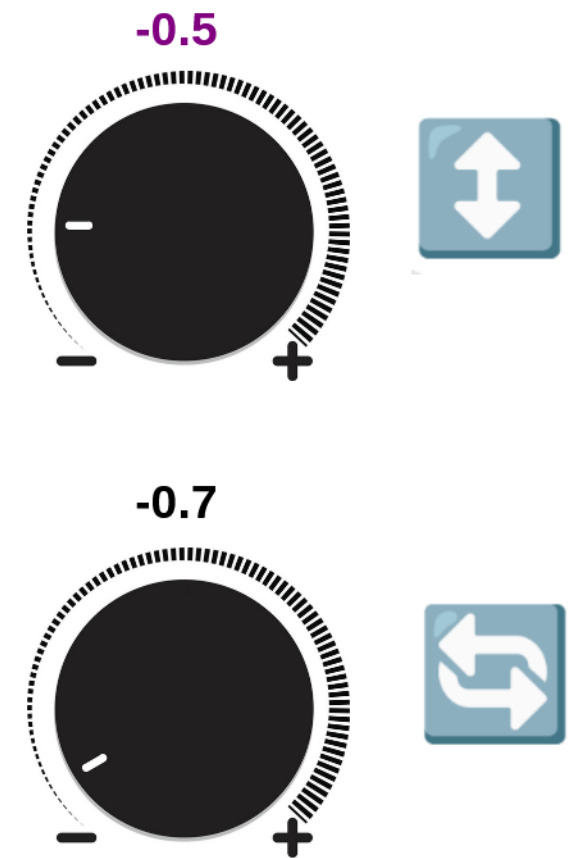
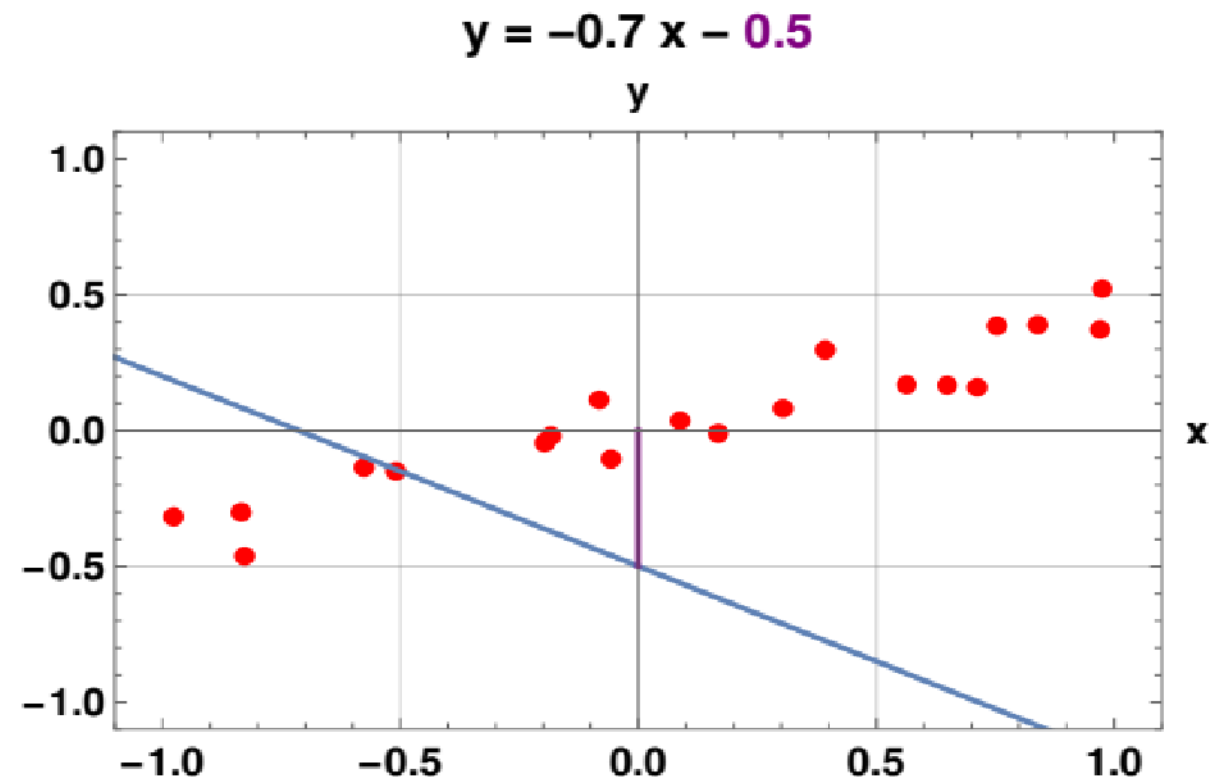

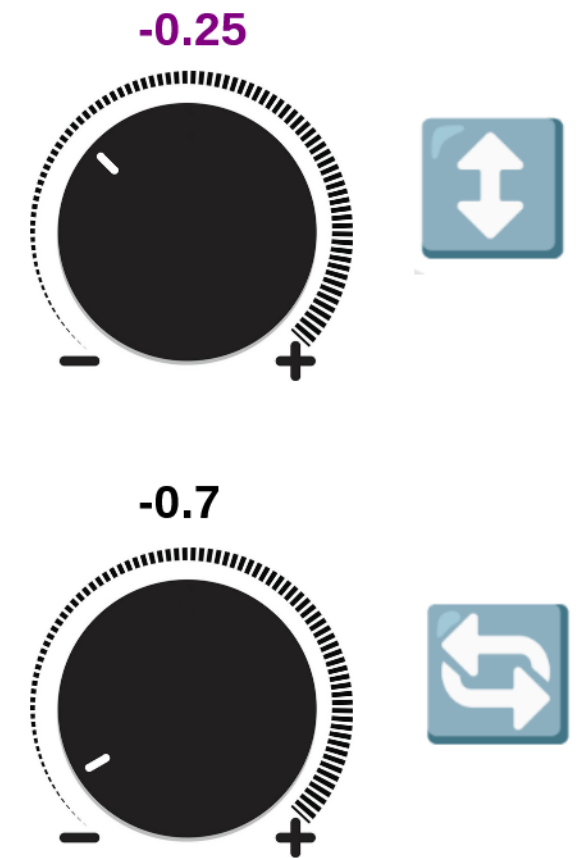
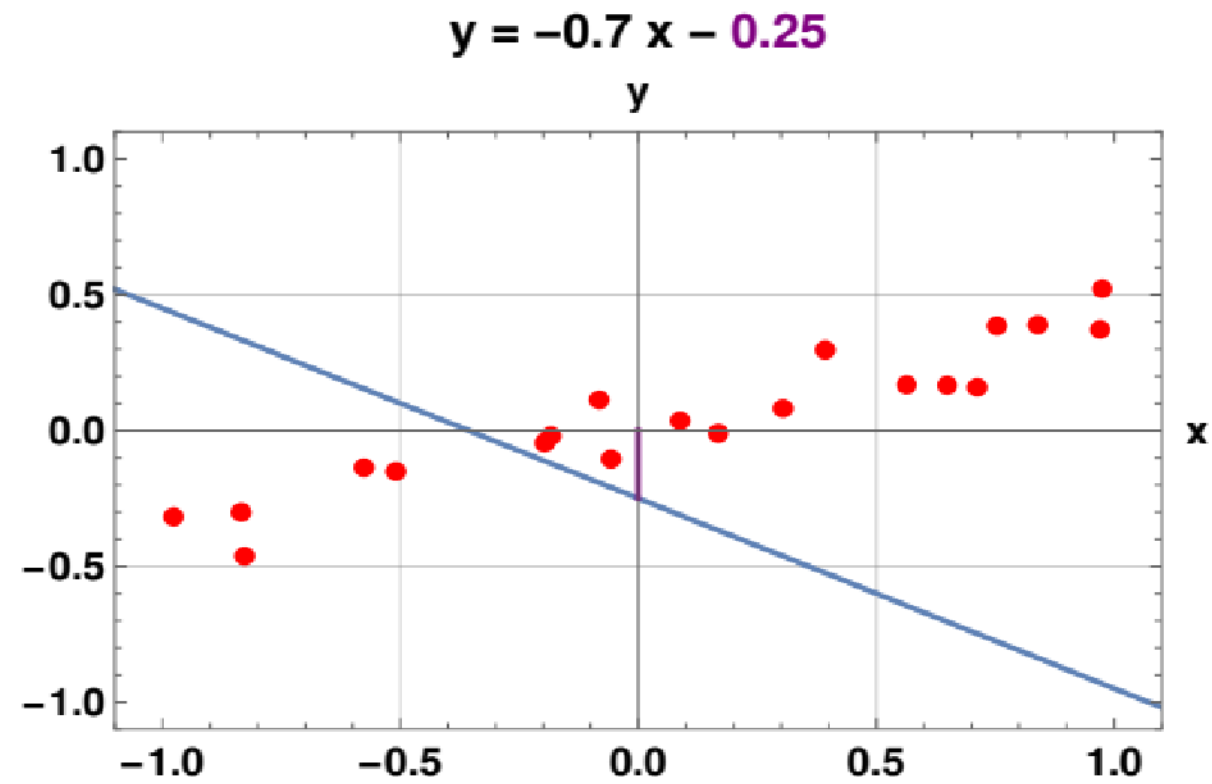

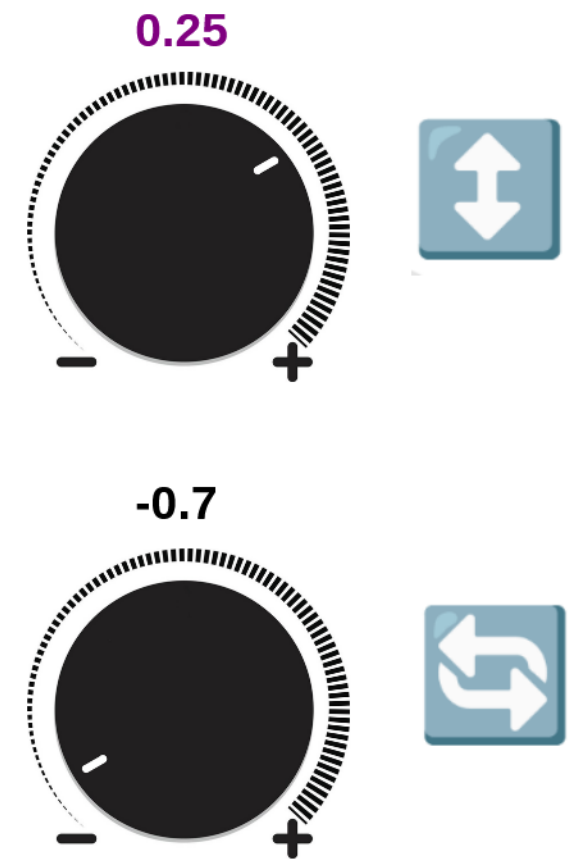
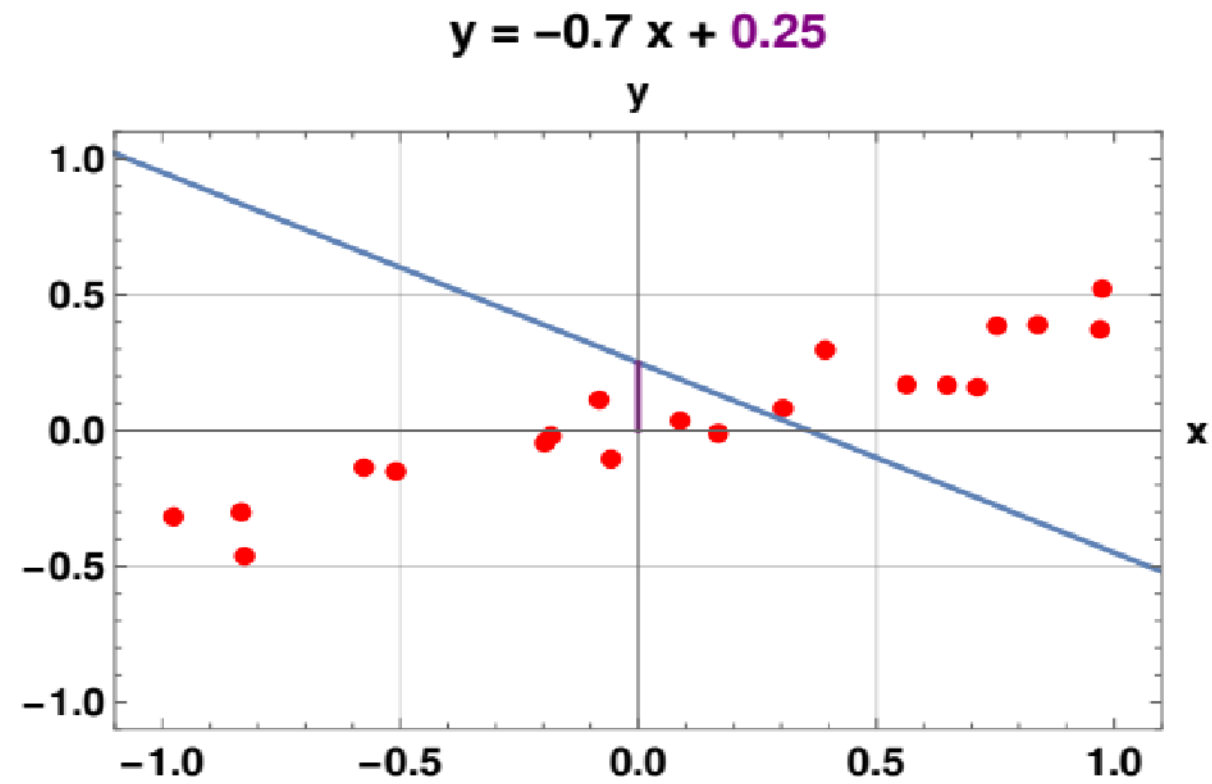

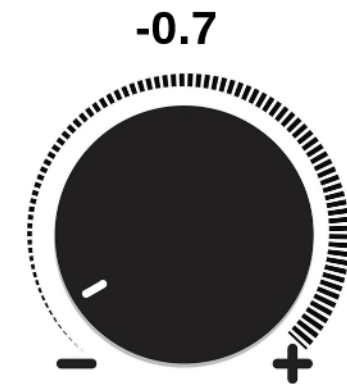
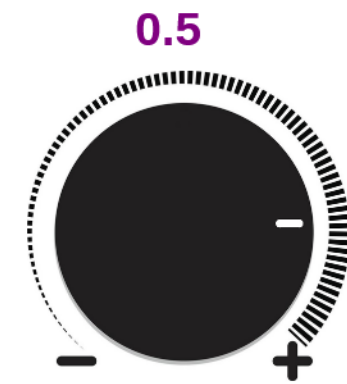
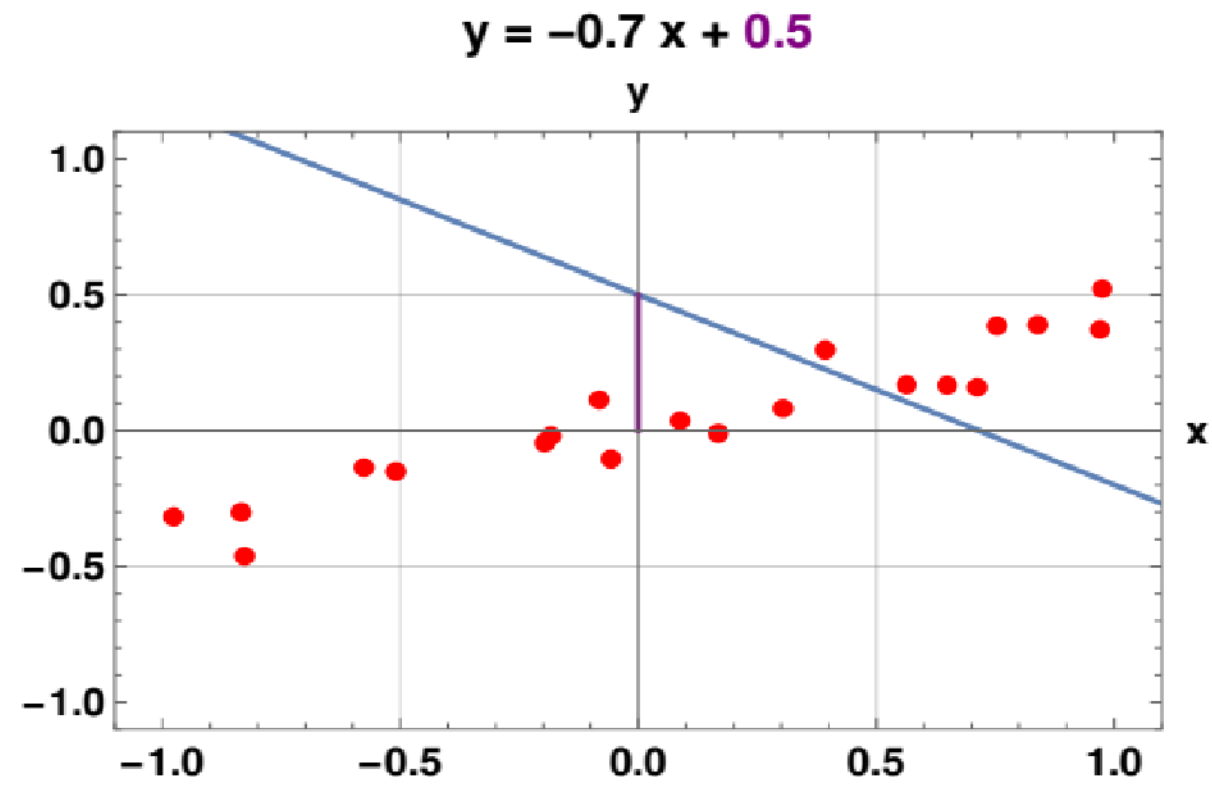

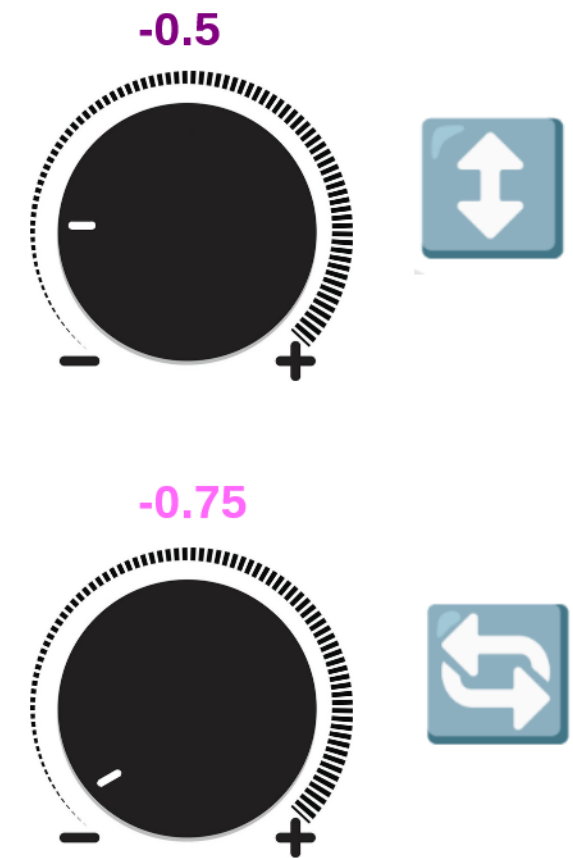
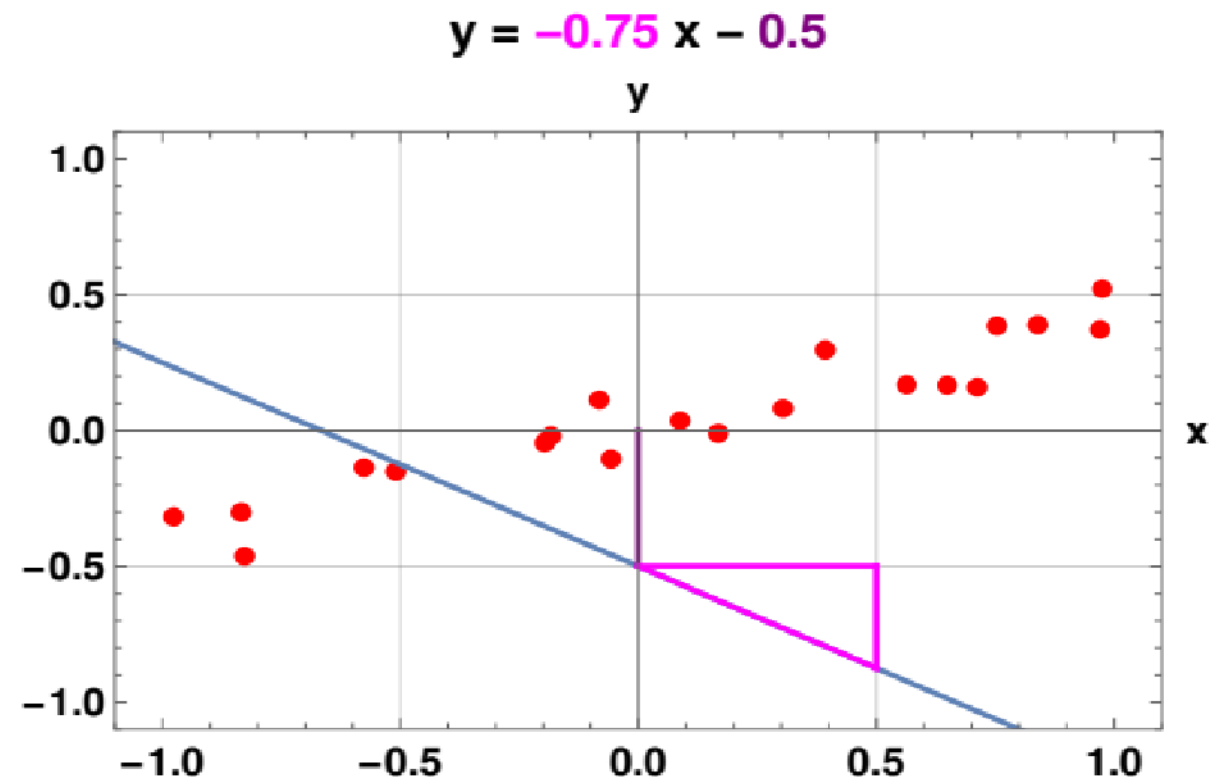

$$y = -0.5x - 0.5$$

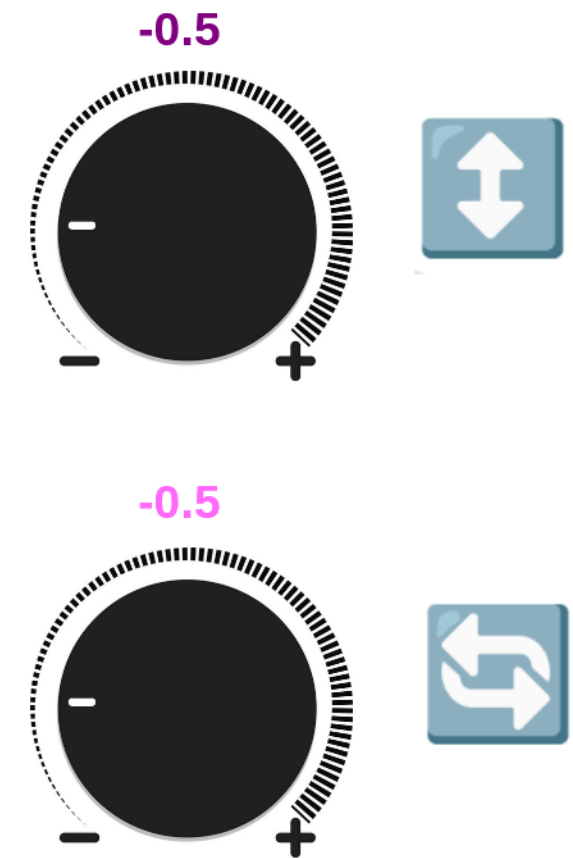
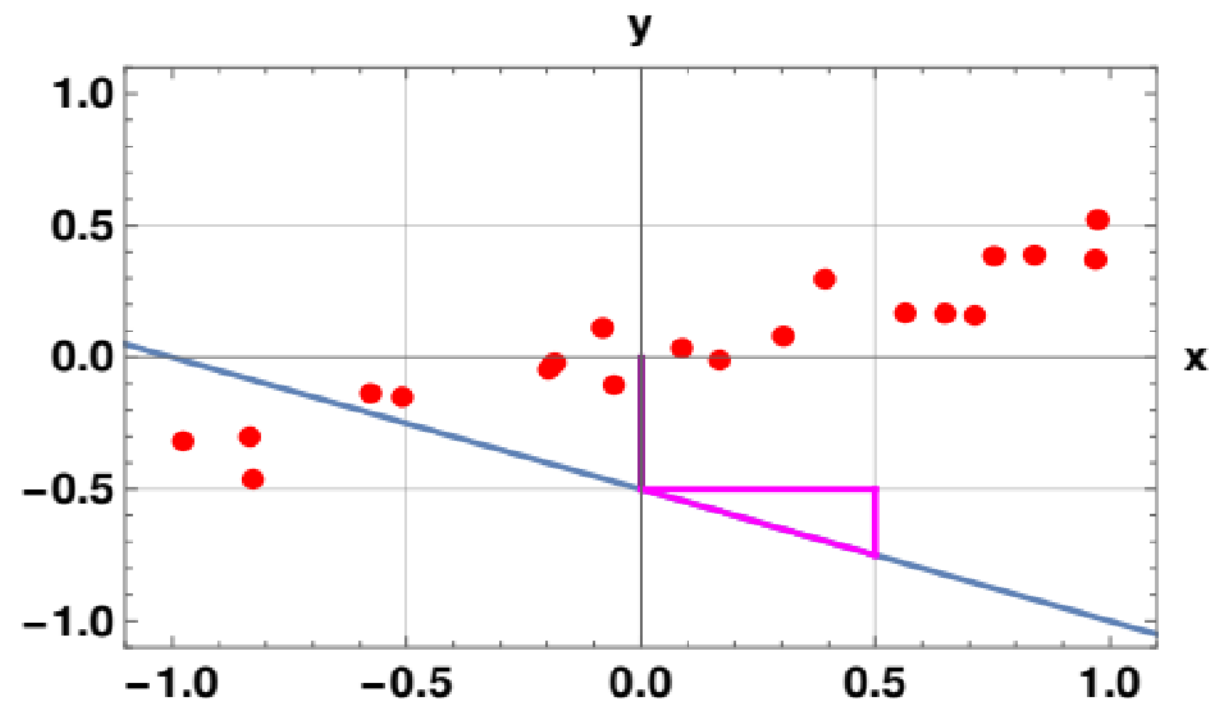

$$y = -0.25x - 0.5$$

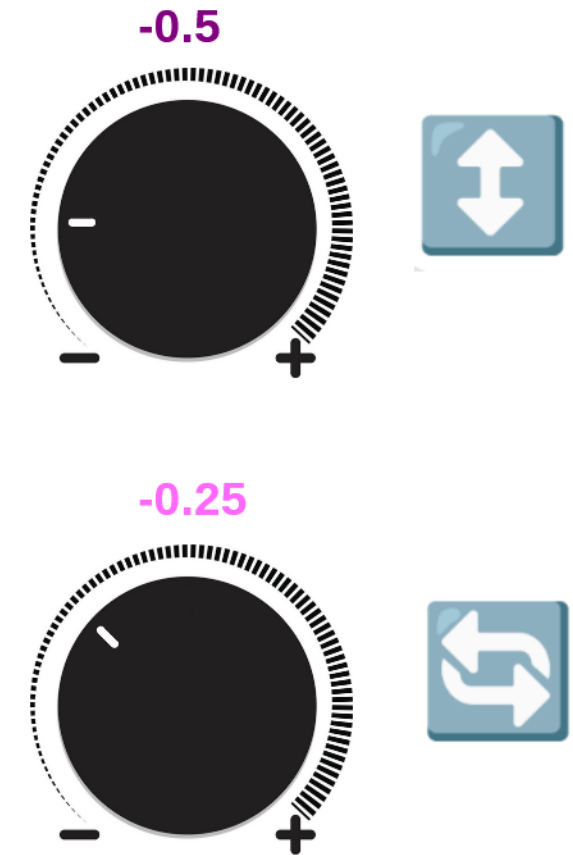
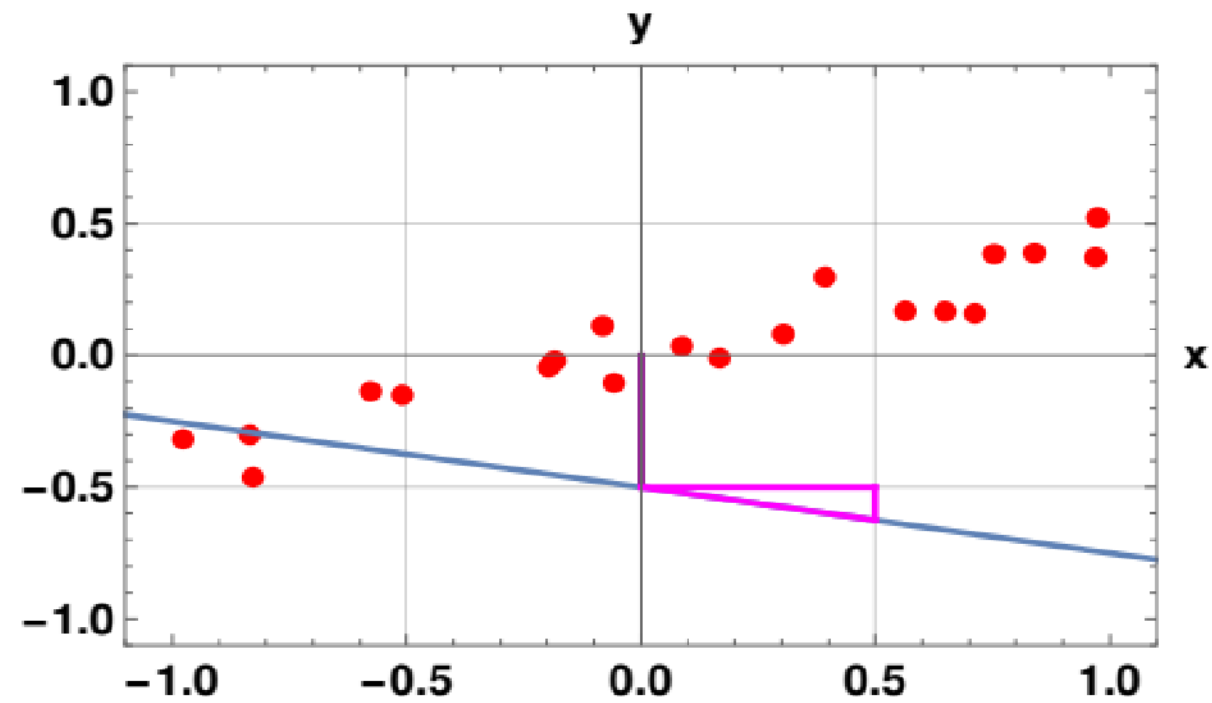

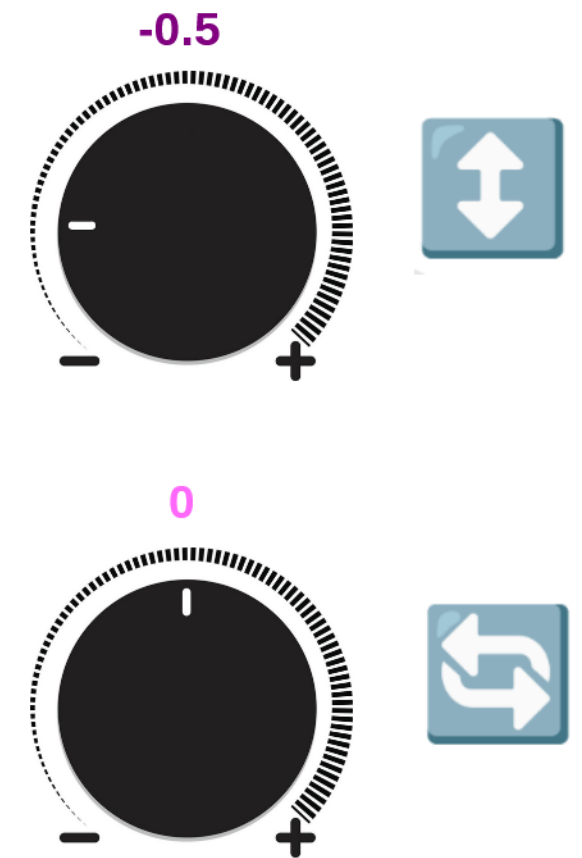
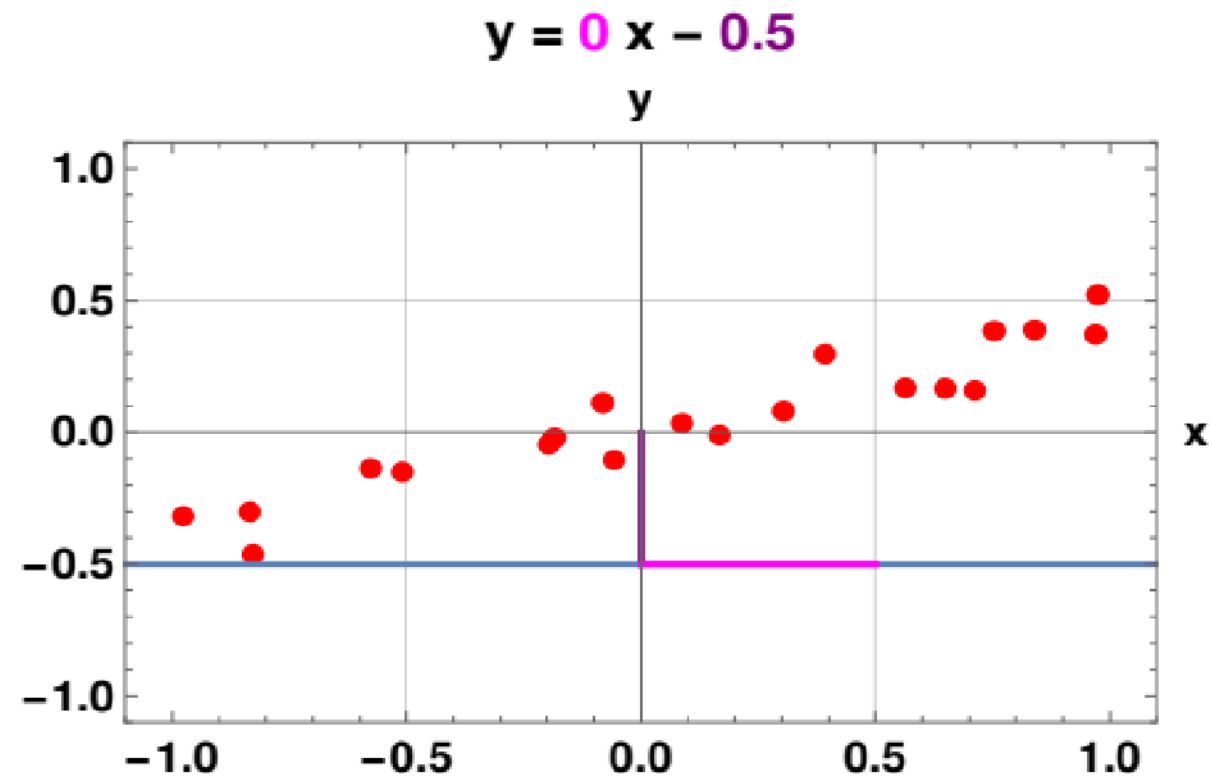

$$y = 0.25x - 0.5$$

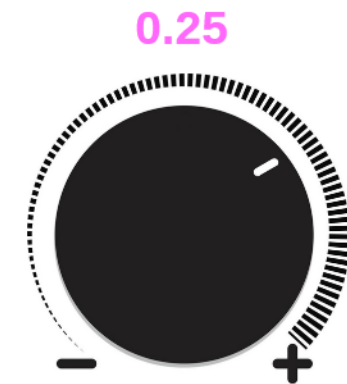
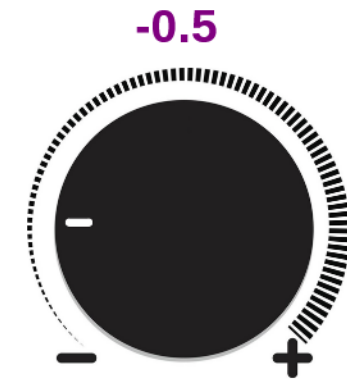
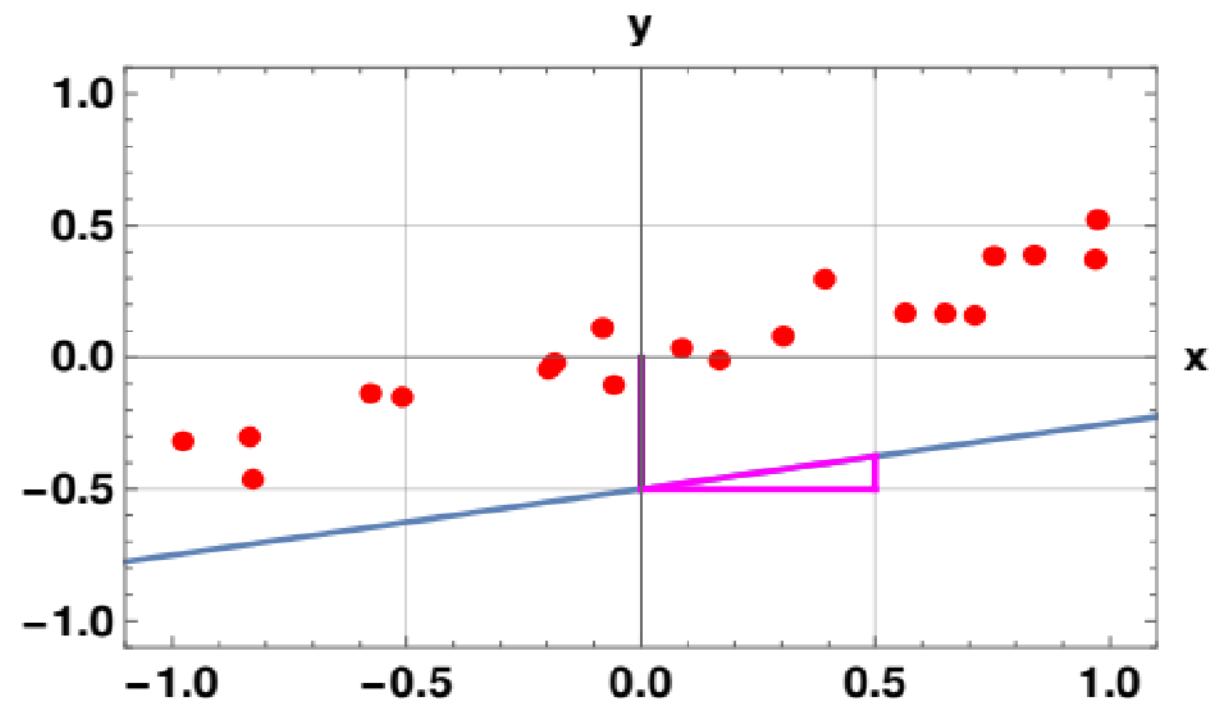

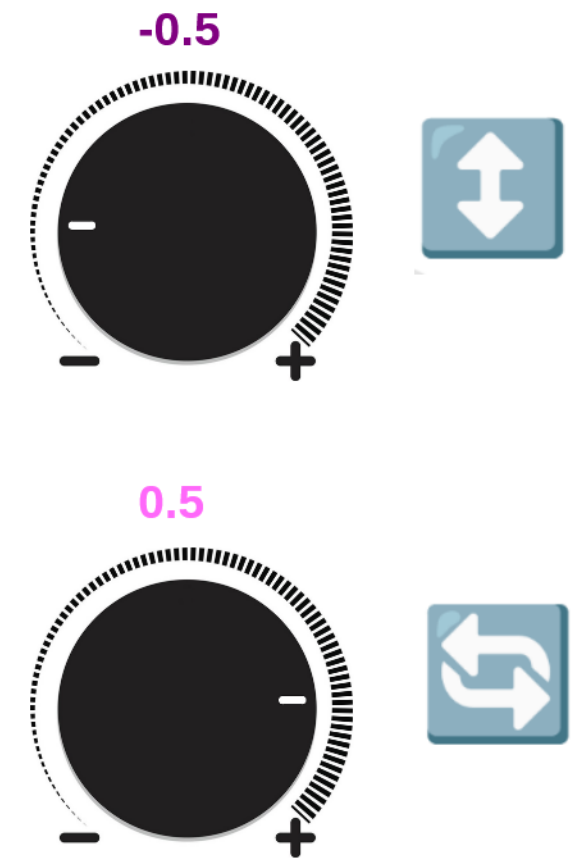
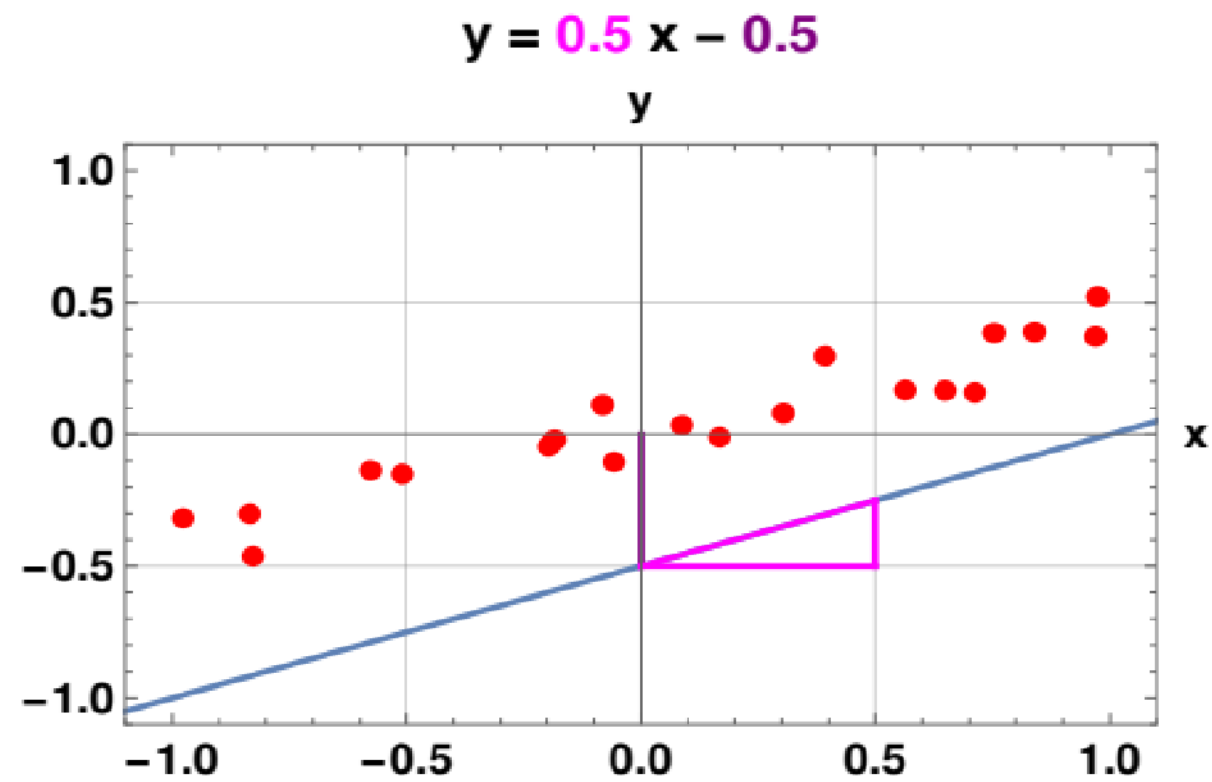

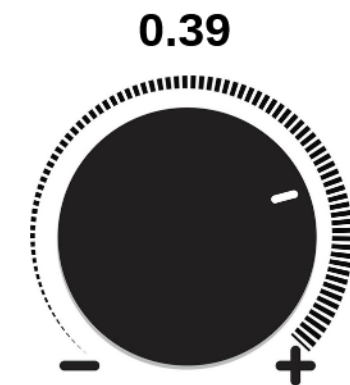
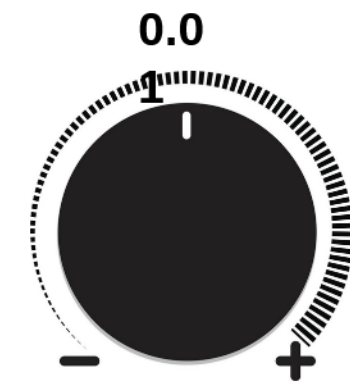
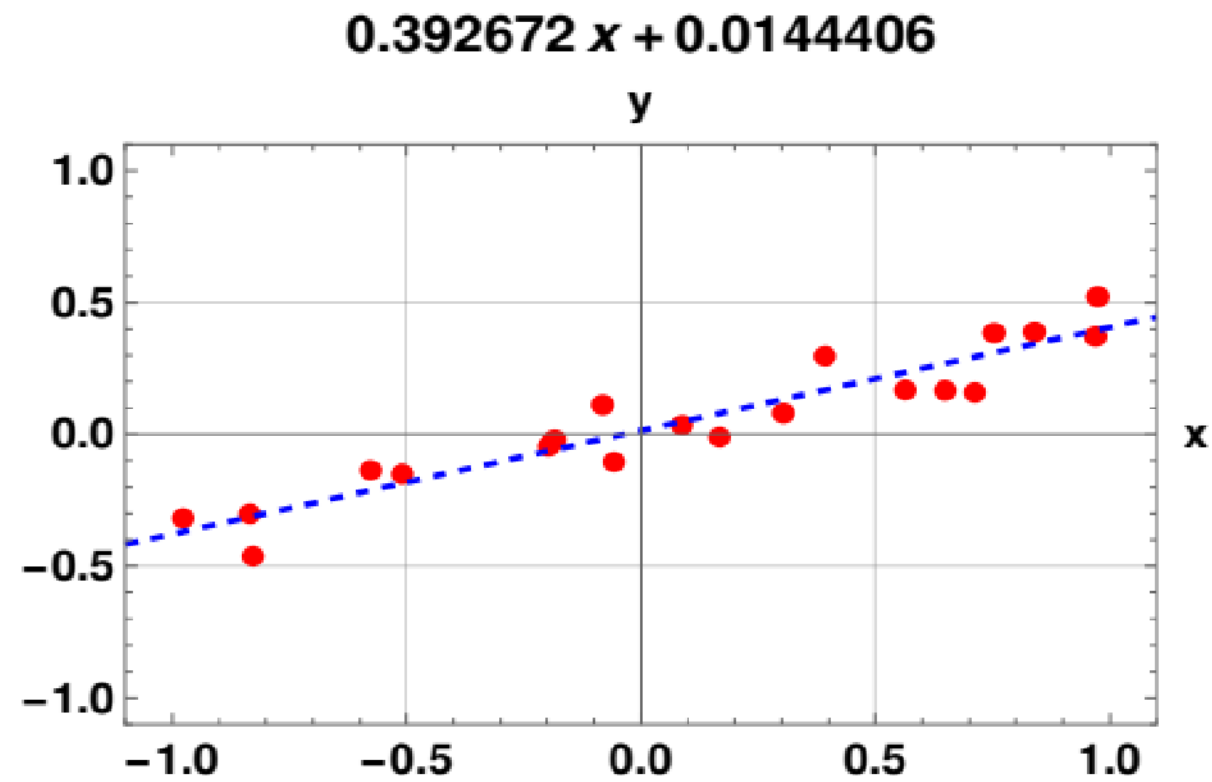

Concept: Training an artificial neural network (a universal function approximator)

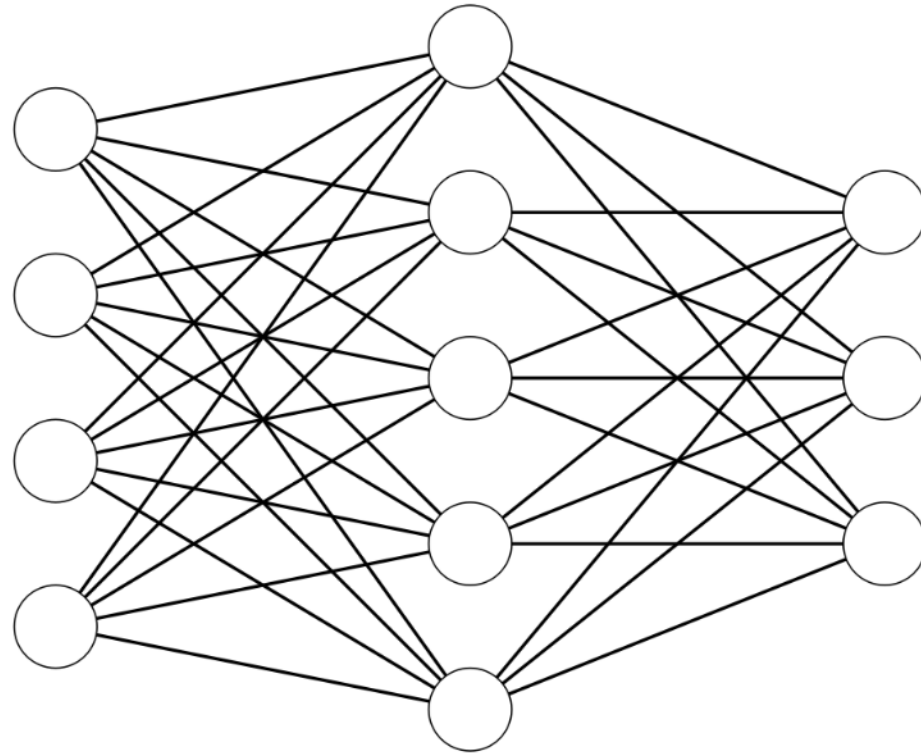

[0.9 cat
0.05 dog
0.05 fox]

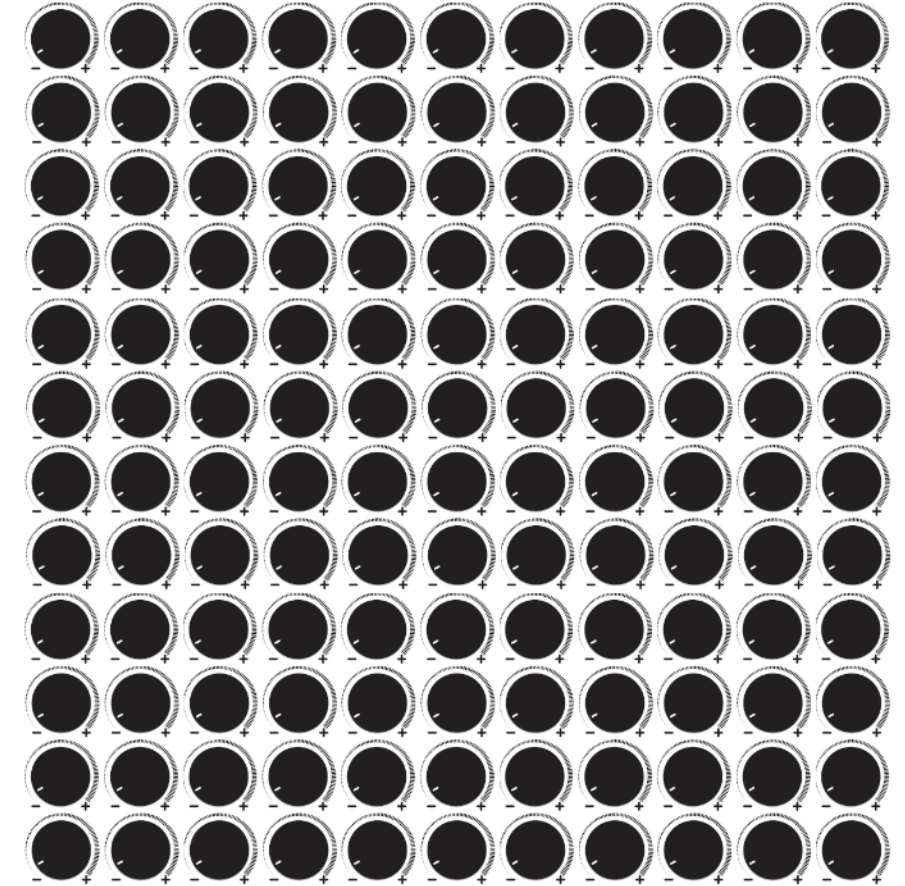

Training a neural network:

- provide training input
- forward pass
- get prediction
- compute loss function (compare)
- compute gradient, update parameters

Concept: Training an artificial neural network (a universal function approximator)

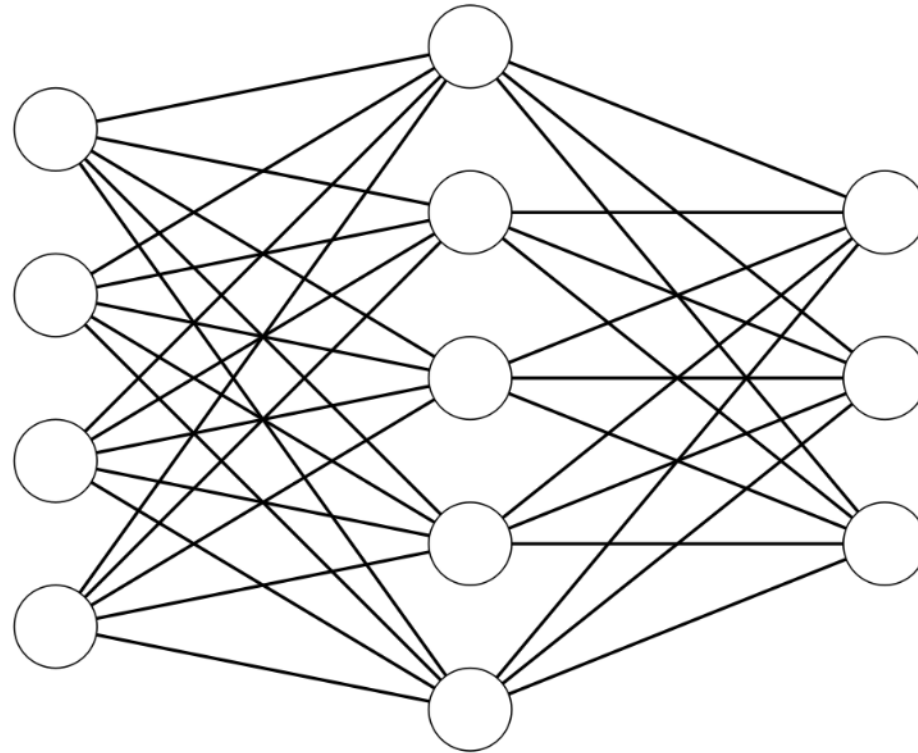

0.9 cat
0.05 dog
0.05 fox

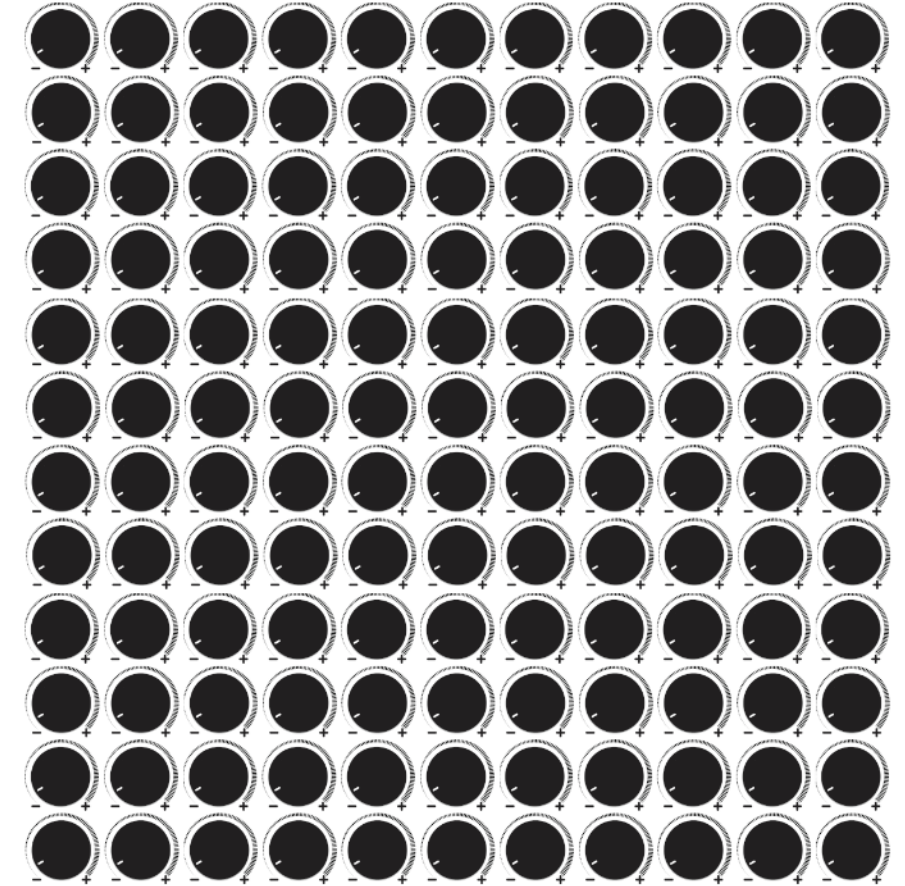

Training a neural network:

- provide training input
- forward pass
- get prediction
- compute loss function (compare)
- compute gradient, update parameters

Number of parameters from 10 thousands to millions

The modern era: Transformer

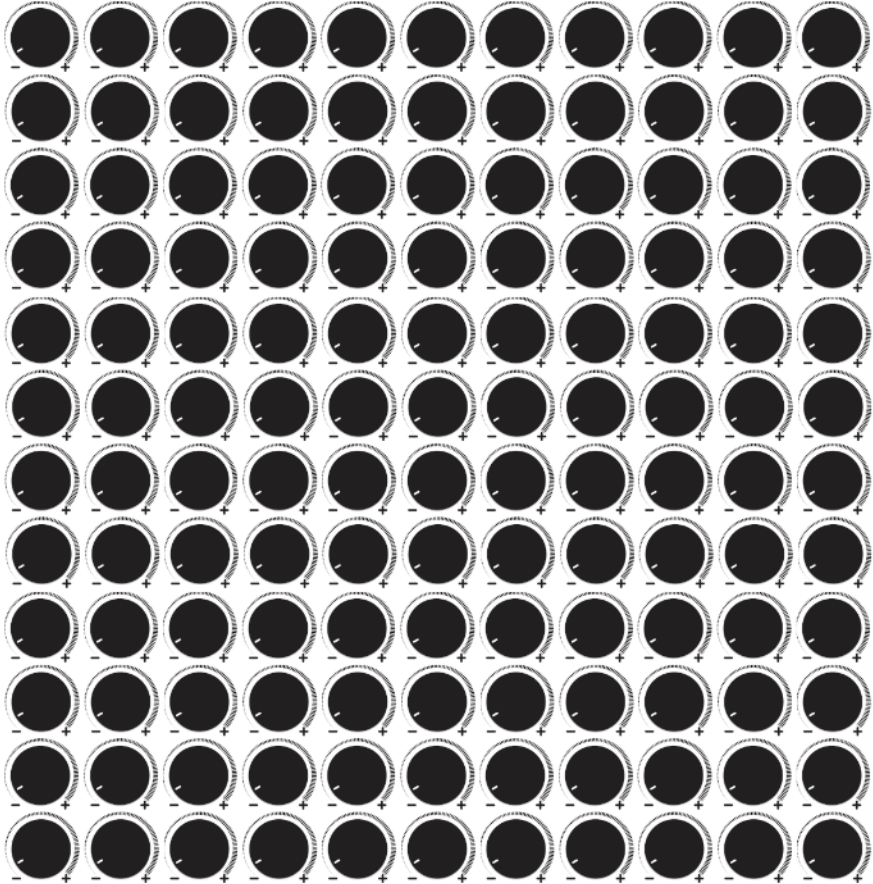
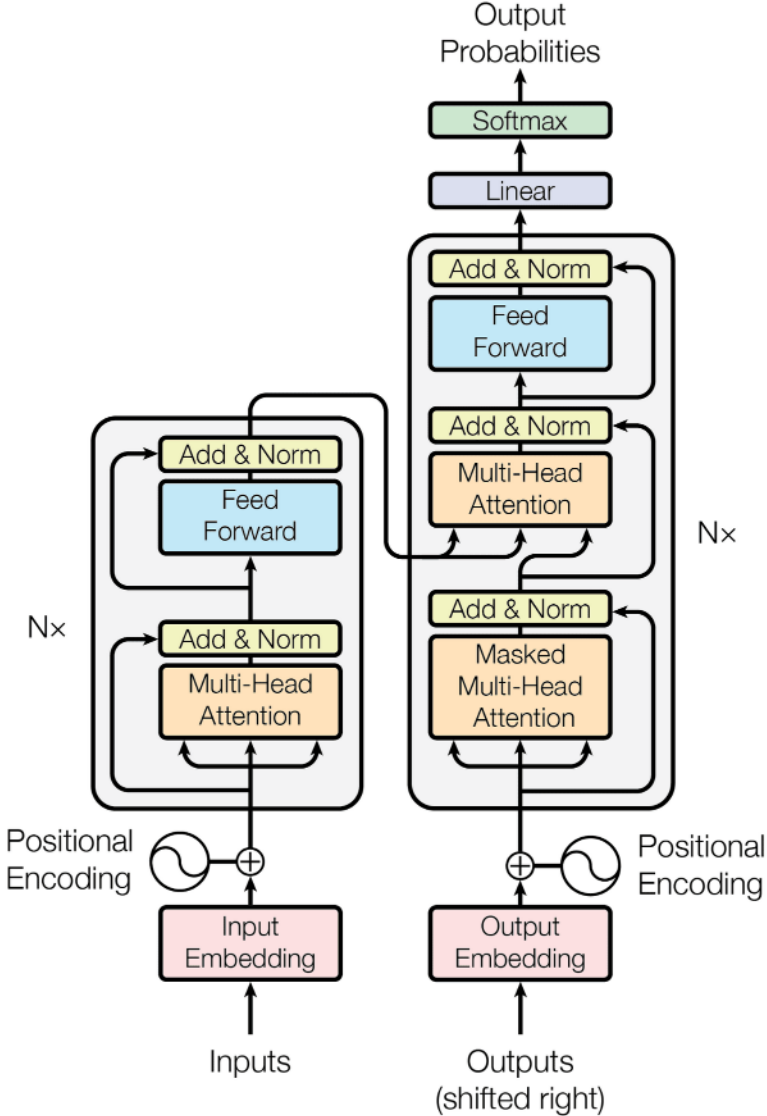

Number of parameters in hundreds of billions to trillions

Source: „Attention is all you need“ arXiv:1706.03762

The modern era: Transformer

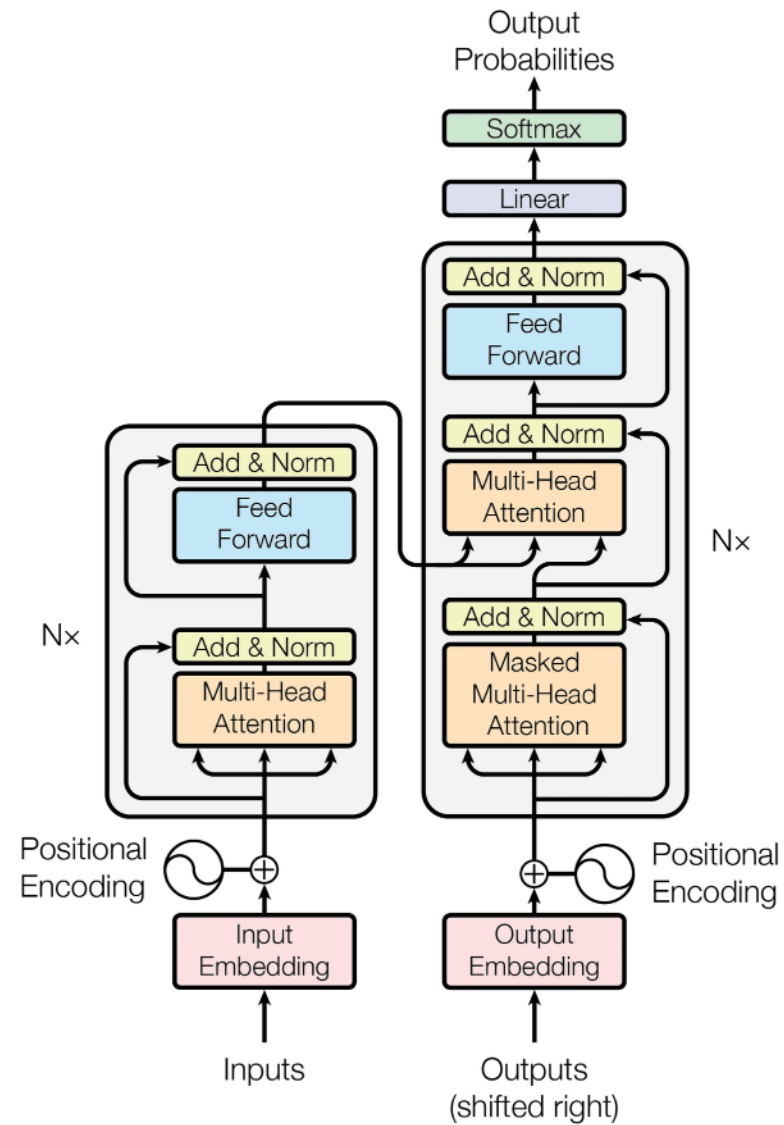

Create an image with huge piles of books. There should be a lectern, on which an open book rests. The floor is strewn with papers that have text printed on them, a candle illuminates the room. The scene has an atmosphere of warmth.



The modern era: Transformer

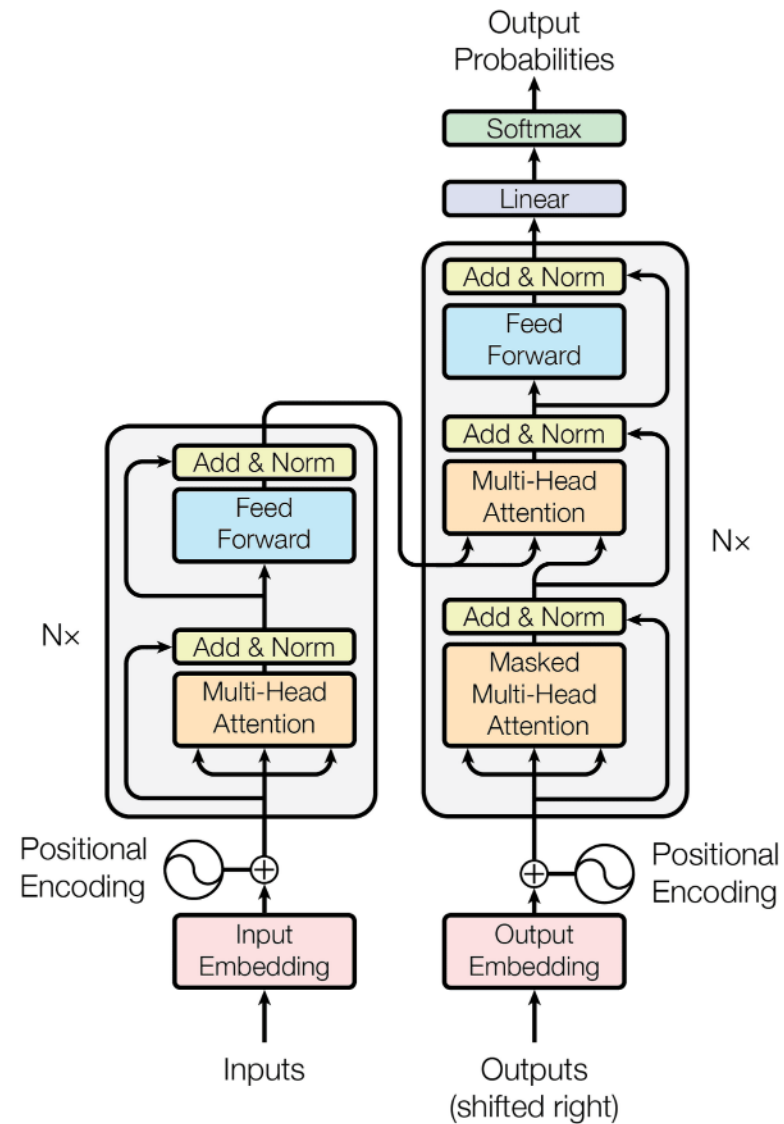

Imagine reading
a long story.
A Transformer is like
a clever helper
who ...

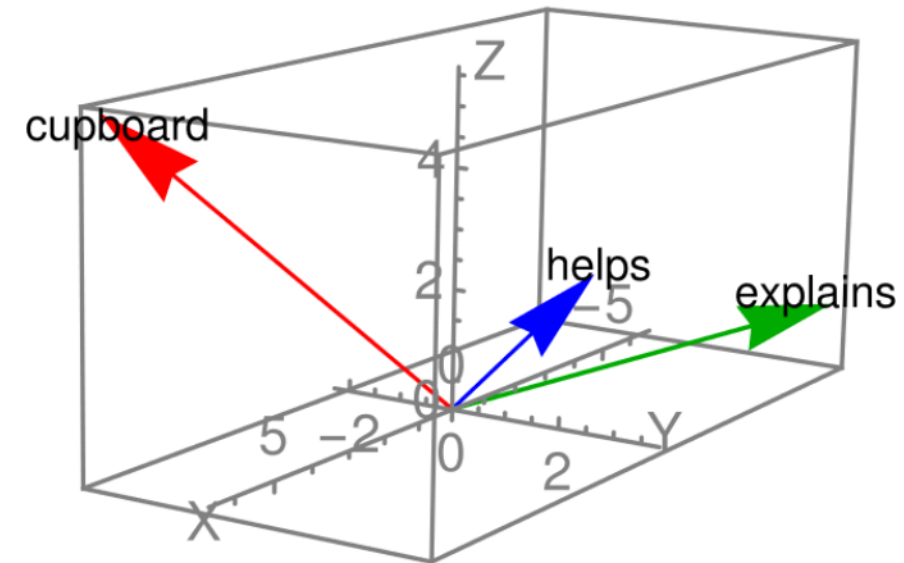

The modern era: Transformer

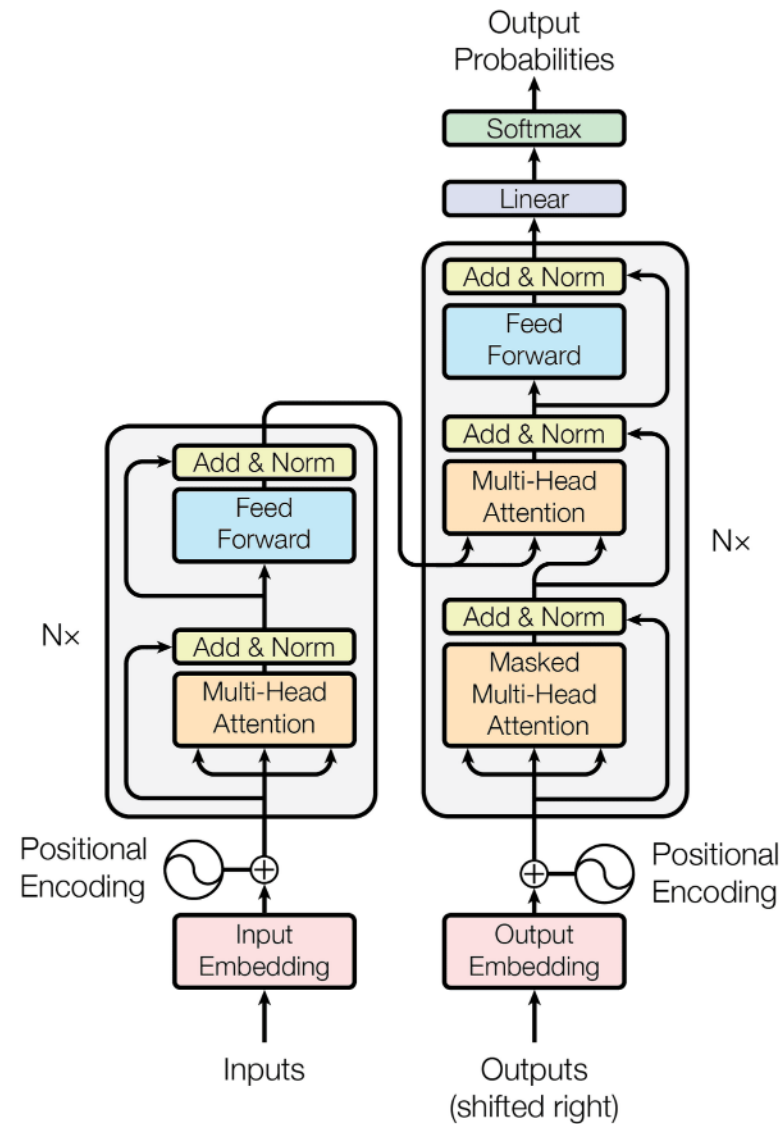

Imagine reading
a big story.
A Transformer is like
a clever helper
who ...

0.30	helps
0.20	listens
0.12	understands
0.10	learns
0.07	remembers
0.06	thinks
0.05	explains
0.04	guides
0.03	highlights
0.02	reads
0.01	talks

The modern era: Transformer

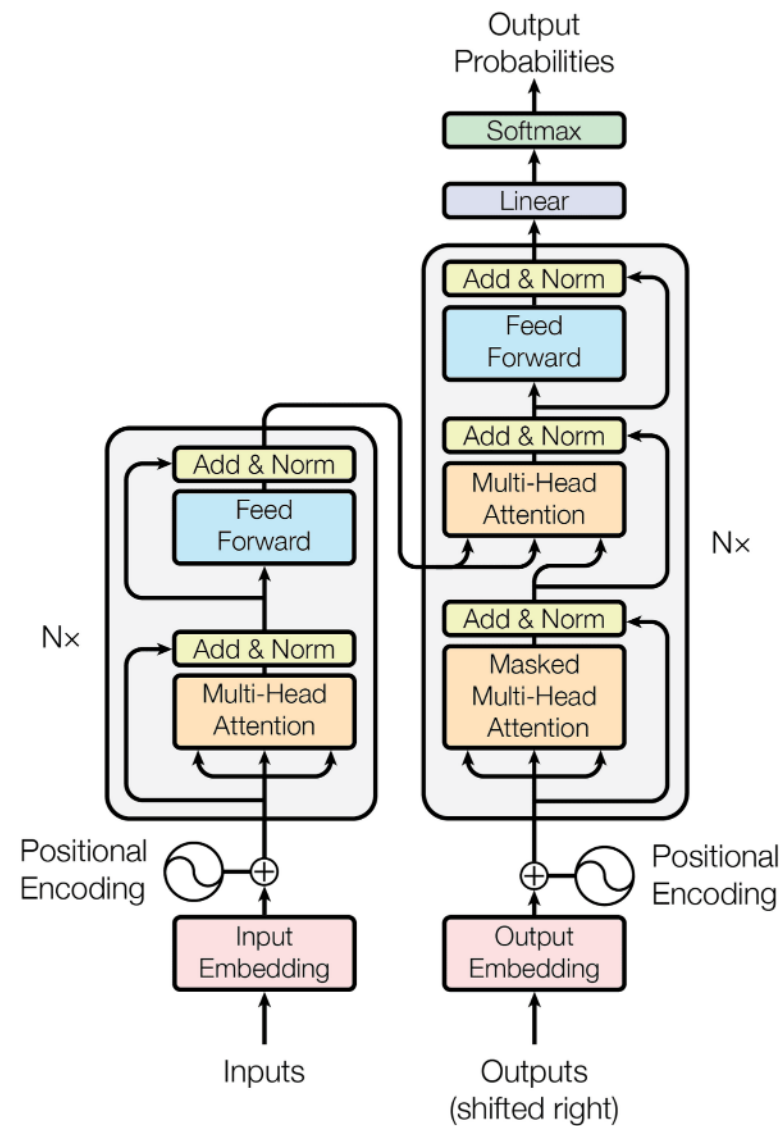

Imagine reading
a long story.
A Transformer is like
a clever helper
who helps...

0.40	you
0.15	to
0.12	understand
0.10	organize
0.07	find
0.05	connect
0.04	grasp
0.03	identify
0.02	distinguish
0.01	focus
0.01	highlight

The modern era: Transformer

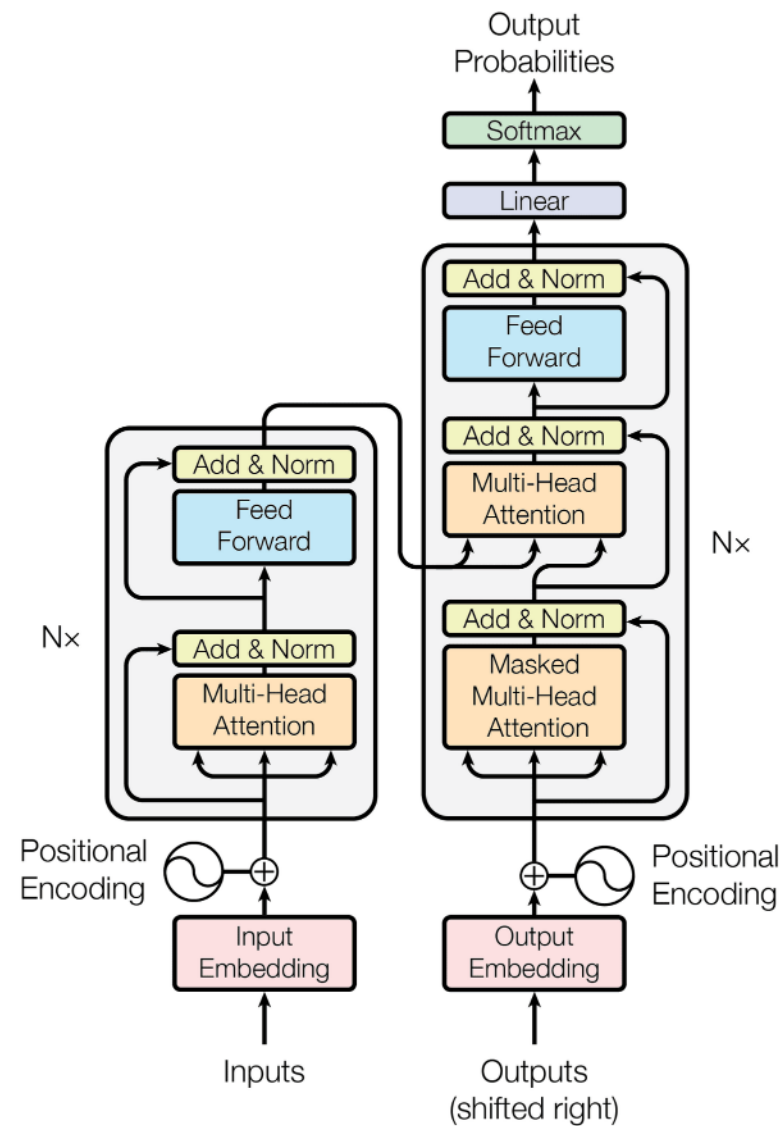

Imagine reading
a long story.
A Transformer is like
a clever helper
who helps you see
which words matter most
and how they fit together,
making the whole story
easy to understand!

How SMEs can start

- Identify one clear source of resource waste
(e.g., energy peaks, idle phases, rework, poor quality, etc)
- Start with a small, contained use case
(e.g., one machine, one process, one production step, etc)
- Leverage existing data
(e.g., machine states, sensor signals, cycle times, energy meters, etc)
- Set a simple, measurable target
(e.g., reduce waste, shorten cycles, lower energy per part, etc)
- Run a short pilot
(e.g., 8-12 weeks, minimal risk, fast insight)
- Scale step-by-step once value is demonstrated

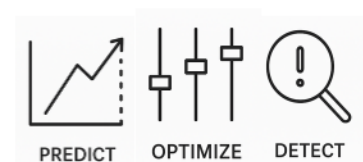

AI delivers the best impact when it reduces waste in a targeted and measurable way.

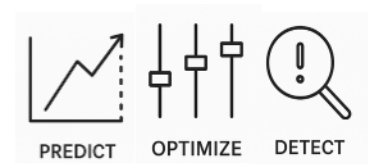

Key Takeaways

- **AI improves predictability, stability and process quality**
- **Energy efficiency emerges naturally by reducing waste**
- **Many benefits can be achieved without new hardware**
- **The fastest value comes from small, focused use cases**
- **A short pilot (8-12 weeks) is usually enough to show measurable impact**

Thank you for your attention!



Andreas Windisch
Head of Research Group Intelligent Vision Applications

JOANNEUM RESEARCH Forschungsgesellschaft mbH
DIGITAL - Institut for Digital Technologies

Steyrergasse 17
8010 Graz

Tel. +43 316 876-5208
andreas.windisch@joanneum.at

www.joanneum.at/digital



www.joanneum.at/digital